

FLIPSIDE FLOOR ANCHORING INSTRUCTIONS

- Step 1: Using the pre-drilled holes in the metal legs, place the unit in the desired location and mark each screw location.
- Step 2: Using a ½" diameter concrete drill bit, make a minimum size hole of ¾" deep into the concrete at each screw location to insert the expansion anchor (Figure A).
- Step 3: Using a hammer, install the expansion anchors into the drilled holes until it is flush with the concrete (Figure B).
- Step 4: Align the legs with the expansion anchors and secure the unit with four hex bolts. A total of two bolts per leg are required (Figure C).

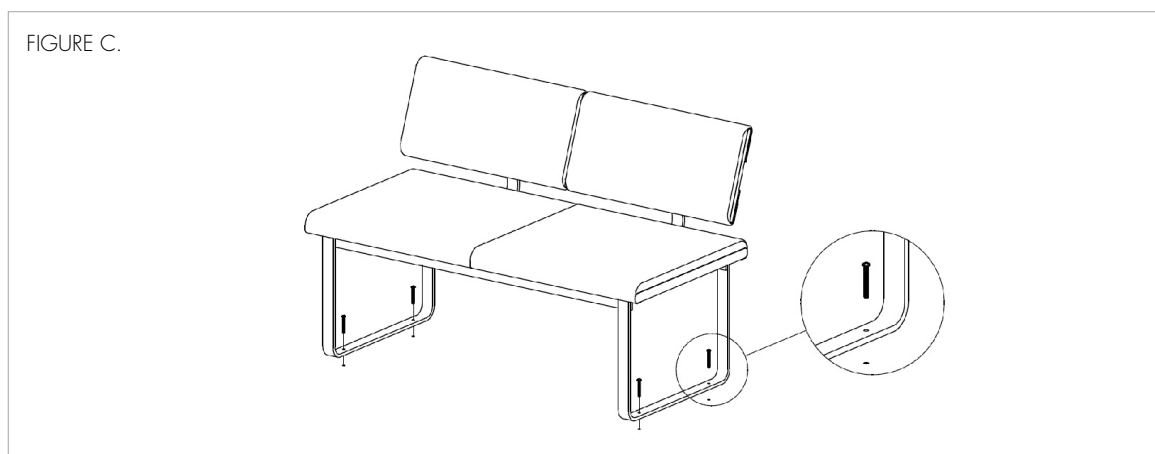
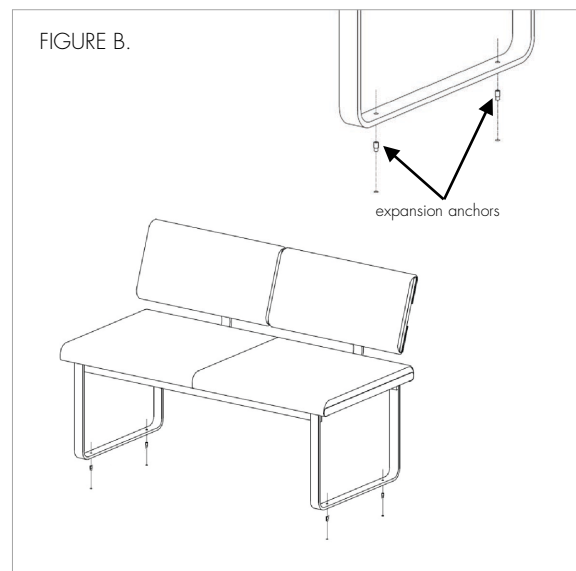
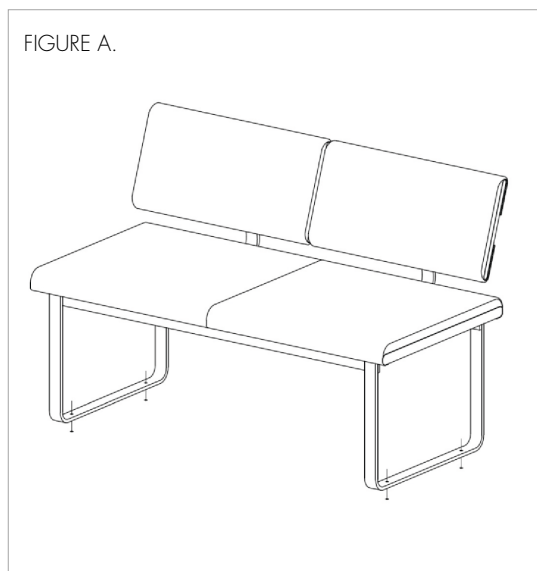

If you require additional assistance, please contact Arcadia Client Services at 800.585.5957.