

ISO RIGHT TABLET INSTALLATION INSTRUCTIONS

Hardware Included:

[A] 1/4-20 countersink machine screw (5)

[B] 1/4-28 x 0.625" pan head machine screw (1)

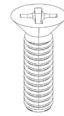

[A]



[B]

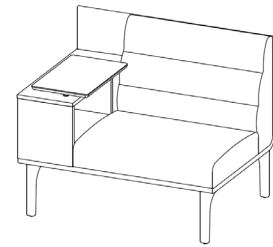

IMPORTANT – HARDWARE IS SPECIFIC FOR THE ASSEMBLY OF EACH COMPONENT. MAKE SURE THE CORRECT ITEMS ARE USED AS DIRECTED AND IDENTIFIED BELOW.

Step 1: Align the top plate of the tablet mech to the underside of the table top and affix together with five 1/4-20 countersink machine screws (Figure A).

Step 2: Align the tablet bracket to the cubby bracket, with the horizontal slot facing the seat of the unit. Secure together with the 1/4-28 x 0.625" pan head machine screw (Figure B).

FIGURE A

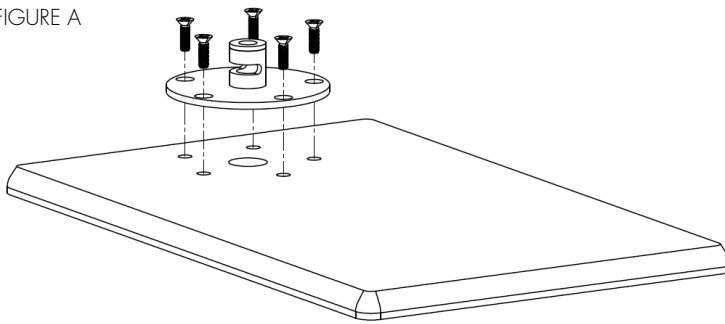
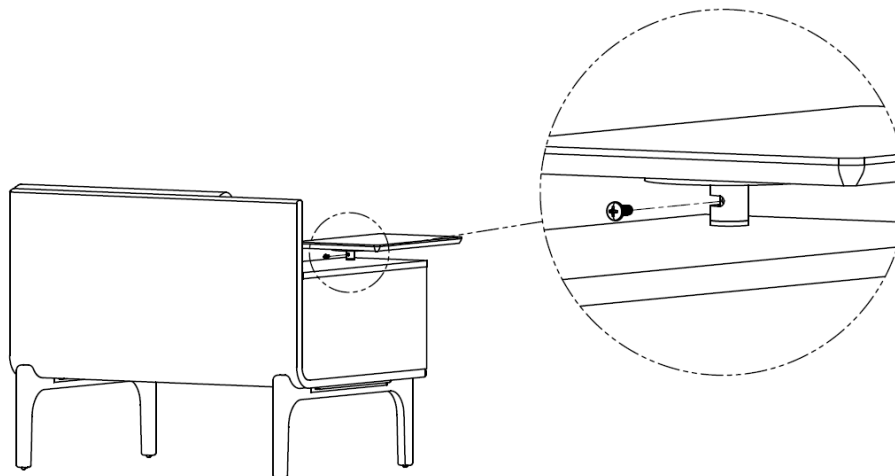

FIGURE B



If you require additional assistance, please contact Arcadia Client Services at 800.585.5957.