

ISO MODELS WITH PANELS ASSEMBLY INSTRUCTIONS

Hardware Included:

[A] 1/4-20 x 1.25" pan head bolt (12)

[B] 1/4-20 x 1.1875" flat head bolt (16)

[C] 1/4-20 x .25" flat head bolt (12)

[D] Corner bracket (2)

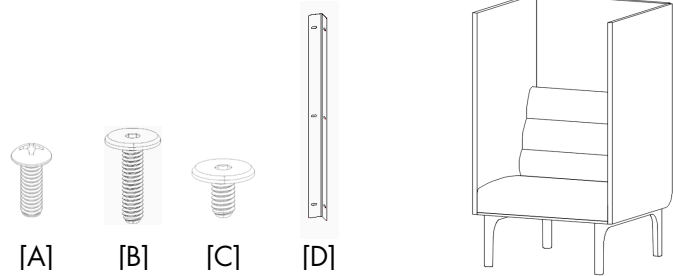

IMPORTANT – HARDWARE IS SPECIFIC FOR THE ASSEMBLY OF EACH COMPONENT. MAKE SURE THE CORRECT ITEMS ARE USED AS DIRECTED AND IDENTIFIED BELOW.

****UNIT REQUIRES TWO PEOPLE FOR INSTALLATION****

IF UNIT IS SHIPPED WITH LEGS PRE-INSTALLED, SKIP STEPS 1 & 2

Step 1: Gently place the unit on its side and locate the holes with pre-inserted t-nuts where the legs will attach (Figure A).

Step 2: Attach each leg by securing with (6) 1/4-20 x 1.25" pan head bolts [A] into the pre-inserted t-nuts (Figure B).

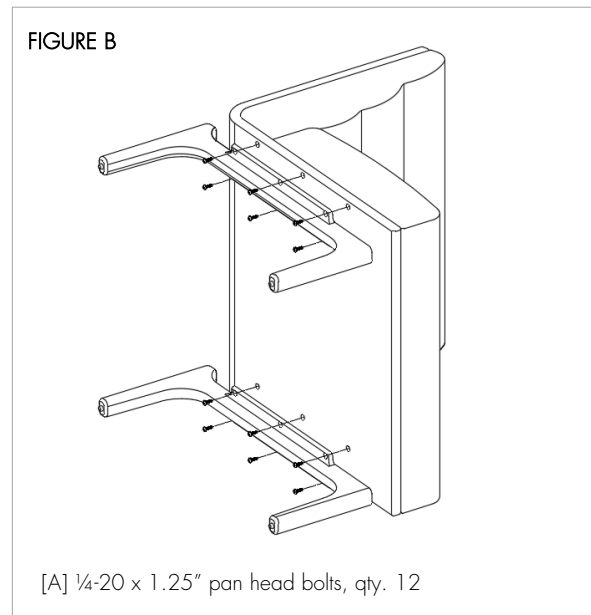
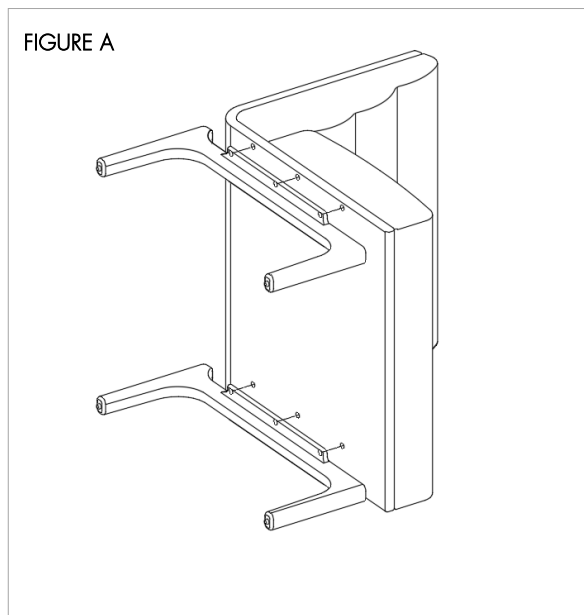

Note: Upon completion of Step 2, return the unit to upright position by lifting unit. Do not tilt or lean unit to upright position.

continued on next page

- Step 3: Open the privacy panel to reveal the attachment holes. Starting with the back of the chair, align the holes with the pre-inserted t-nuts and secure with (6) ¼-20 x 1.1875" flat head bolts [B]. Follow with side panels using (5) ¼-20 x 1.1875" flat head bolts [B] per side (Figure C).
- Step 4: Using an allen wrench, align each corner bracket [D] to a side panel, thread the (3) ¼-20 x .25" flat head bolts [C] into the pre-inserted t-nuts and securely tighten (Figure D).
- Step 5: Complete the installation of the corner bracket by securing the remaining (6) ¼-20 x .25" flat head binding bolts [C] onto the back panel through the pre-inserted t-nuts (Figure E).
- Step 6: Once the panels have been properly secured, remove the yellow masking tape covering the Velcro and firmly press the panels together (Figure F).

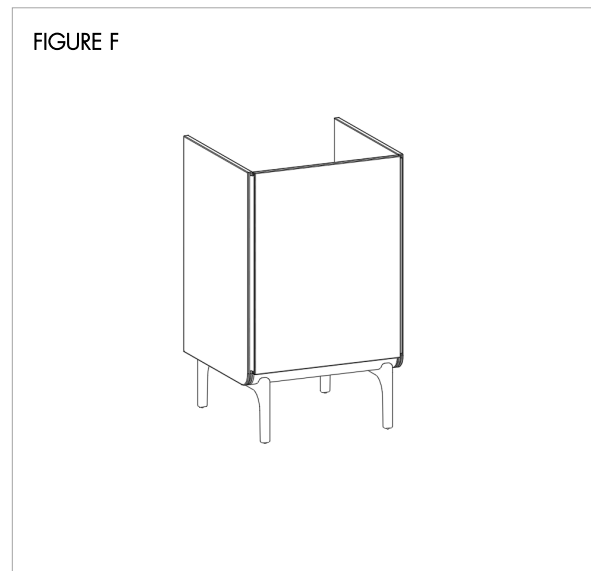
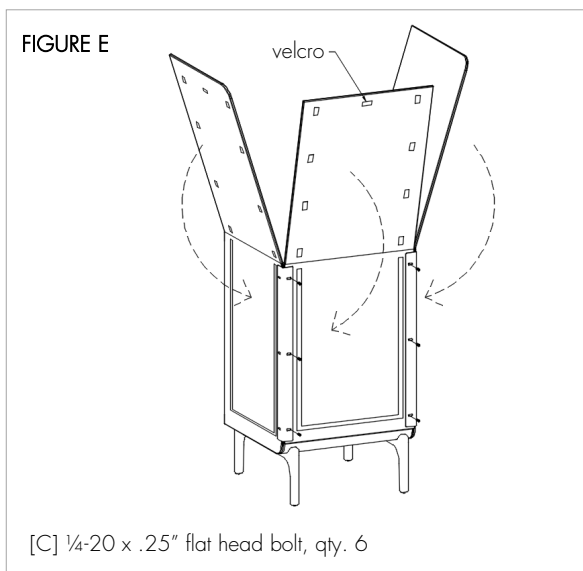
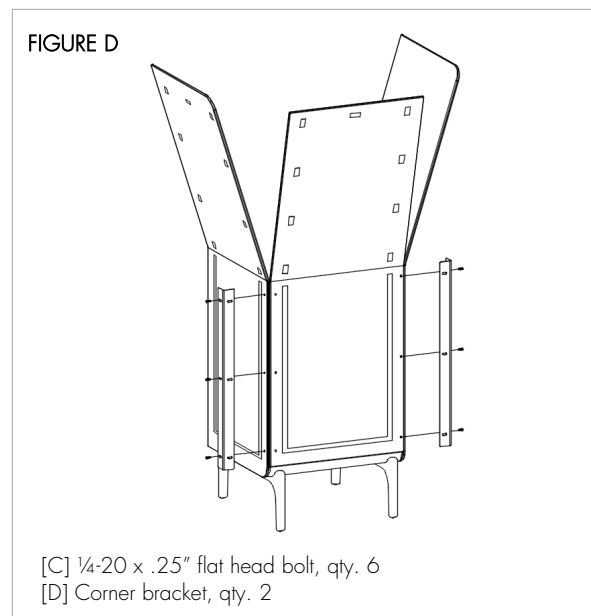
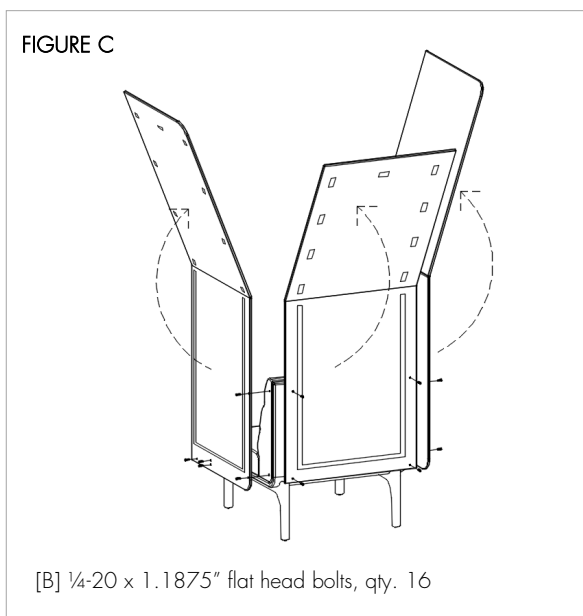

If you require additional assistance, please contact Arcadia Client Services at 800.585.5957.