

ISO CONFIGURATIONS WITH PANELS – T-BRACKET ASSEMBLY INSTRUCTIONS

Hardware Included (quantity varies per configuration):

[A] 1/4-20 x 1.25" pan head bolt (24)

[B] 1/4-20 x 1.1875" flat head bolt (27)

[C] 1/4-20 x .25" flat head bolt (21)

[D] Corner bracket

[E] T-bracket

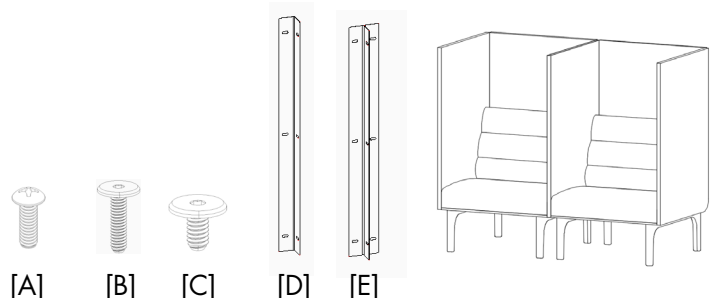

IMPORTANT – HARDWARE IS SPECIFIC FOR THE ASSEMBLY OF EACH COMPONENT. MAKE SURE THE CORRECT ITEMS ARE USED AS DIRECTED AND IDENTIFIED BELOW.

****UNIT REQUIRES TWO PEOPLE FOR INSTALLATION****

IF UNIT IS SHIPPED WITH LEGS PRE-INSTALLED, SKIP STEPS 1 & 2

Step 1: Gently place the unit on its side and locate the holes with pre-inserted t-nuts where the legs will attach (Figure A).

Step 2: Attach each leg by securing with (6) 1/4-20 x 1.25" pan head bolts [A] into the pre-inserted t-nuts (Figure B).

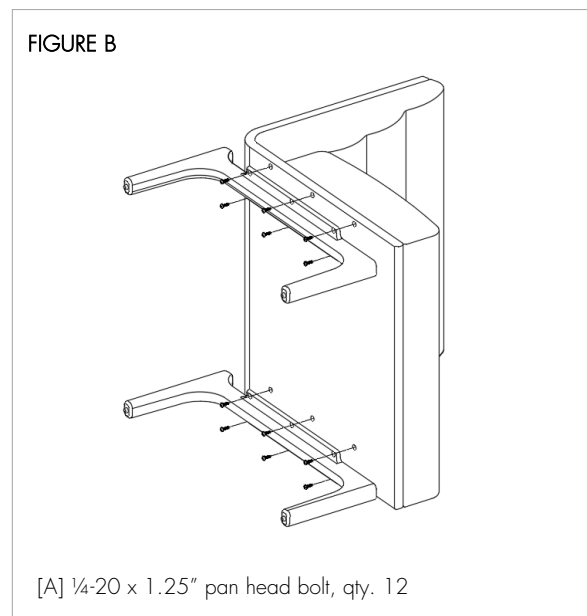
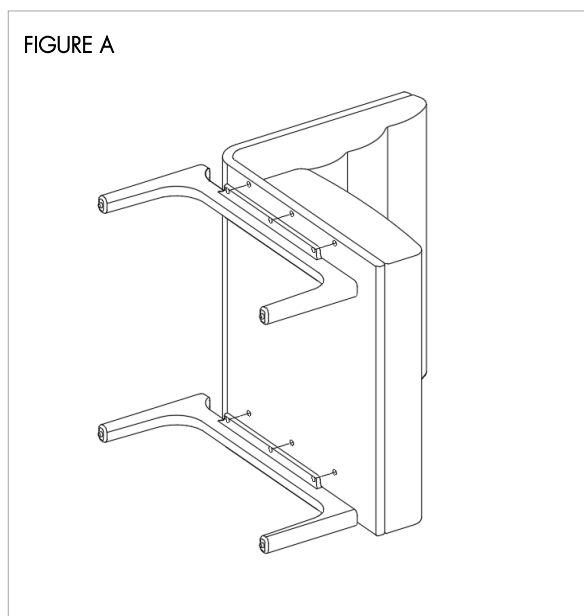

Note: Upon completion of Step 2, return the unit to upright position by lifting unit. Do not tilt or lean unit to upright position.

continued on next page

- Step 3: Open the privacy panel to reveal the attachment holes. Starting with the back of the chair, align the holes with the pre-inserted t-nuts and secure with (4) 1/4-20 x 1.1875" flat head bolt [B]. Follow with side panels using (5) 1/4-20 x 1.1875" flat head bolt [B] per side (Figure C).
- Step 4: Align and secure the Corner bracket [D] to the right side (from the rear view) with an Allen wrench and (3) 1/4-20 x .25" flat head binding bolts [C]. Align and secure the T-bracket [E] to the left side in the same way (Figure D).
- Step 5: Secure each bracket to the back panel with (6) 1/4-20 x .25" flat head bolt [C] into the pre-inserted t-nuts (Figure E).
- Step 6: Once the panels have been properly secured, remove the yellow masking tape covering the Velcro and firmly press the panels together (Figure F).

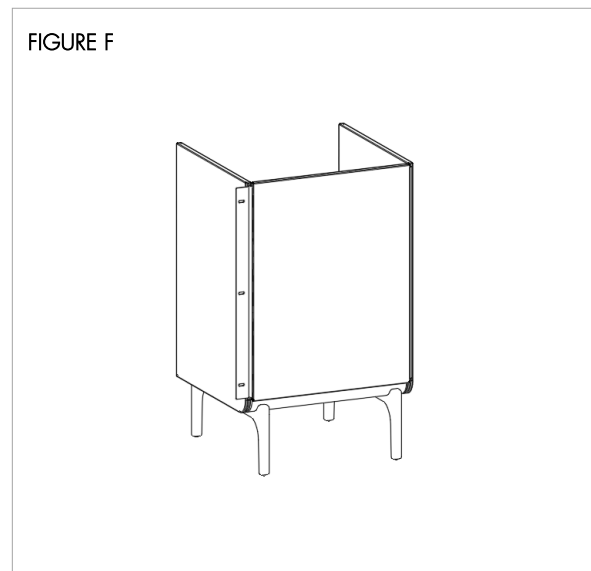
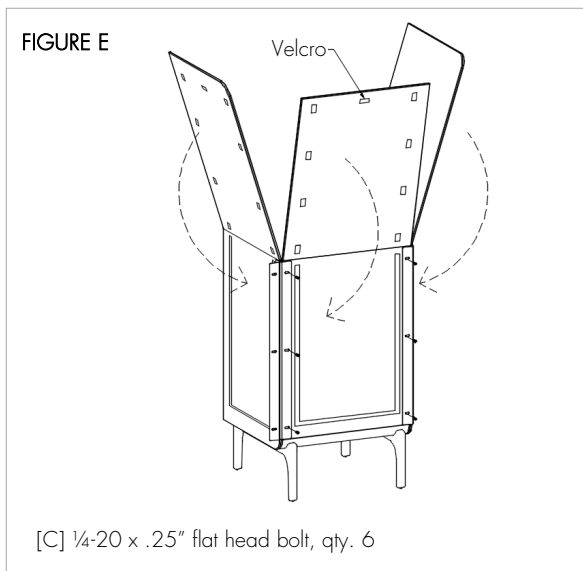
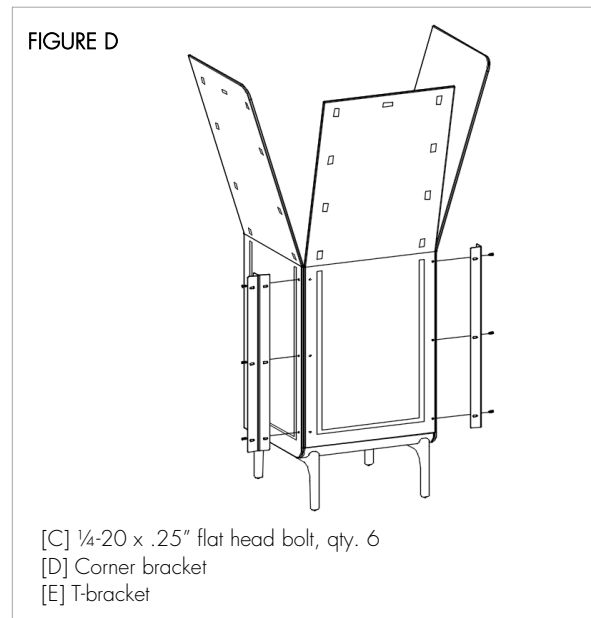
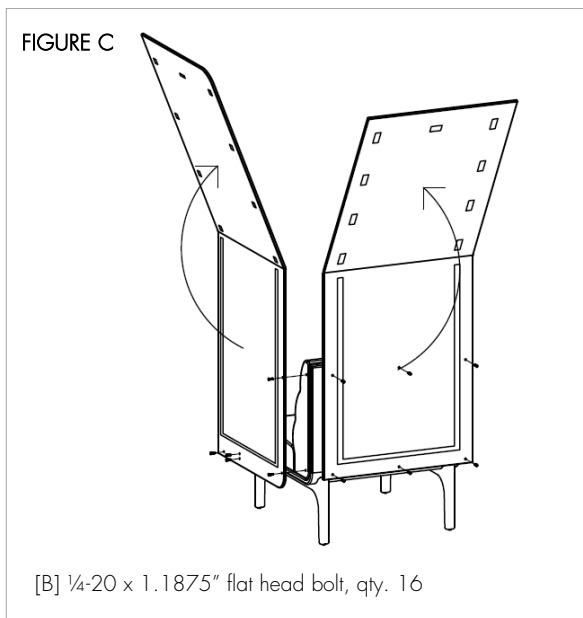

continued on next page

- Step 7: Align and secure the corner bracket to the secondary unit and affix back and left panels (Figure G).
- Step 8: Open the back panel where the other half of the t-bracket will attach and arrange the units as they should be configured. Align the t-bracket from the already installed unit to the pre-inserted t-nuts on the secondary unit. Using an Allen wrench, secure together with (3) 1/4-20 x .25" flat head bolts [C] (Figure H).
- Step 9: Once the panel is properly secured, remove the yellow masking tape covering the Velcro and firmly press the panels together (Figure I).

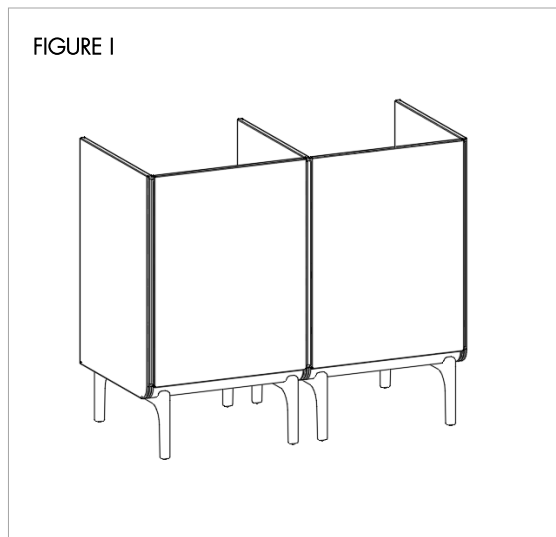
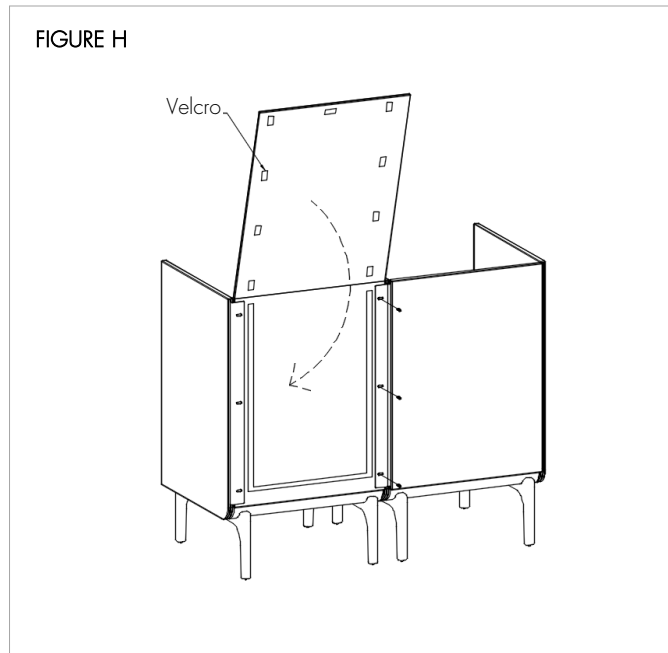
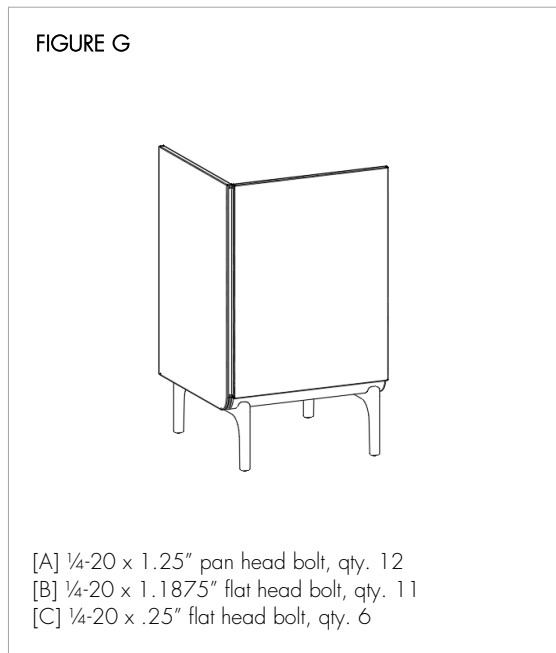

If you require additional assistance, please contact Arcadia Client Services at 800.585.5957.