

ISO CONFIGURATIONS WITH PANELS - STRAIGHT BRACKET ASSEMBLY INSTRUCTIONS

Hardware Included (quantity varies per configuration):

[A] 1/4-20 x 1.25" pan head bolt (12)

[B] 1/4-20 x 1.1875" flat head bolt (16)

[C] 1/4-20 x .25" flat head bolt (12)

[D] Corner bracket

[E] Straight bracket

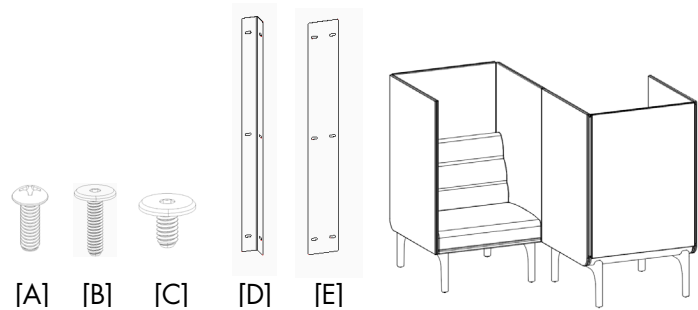

IMPORTANT – HARDWARE IS SPECIFIC FOR THE ASSEMBLY OF EACH COMPONENT. MAKE SURE THE CORRECT ITEMS ARE USED AS DIRECTED AND IDENTIFIED BELOW.

****UNIT REQUIRES TWO PEOPLE FOR INSTALLATION****

IF UNIT IS SHIPPED WITH LEGS PRE-INSTALLED, SKIP STEPS 1 & 2

Step 1: Gently place the unit on its side and locate the holes with pre-inserted t-nuts where the legs will attach (Figure A).

Step 2: Attach each leg by securing with (6) 1/4-20 x 1.25" pan head bolts [A] into the pre-inserted t-nuts (Figure B).

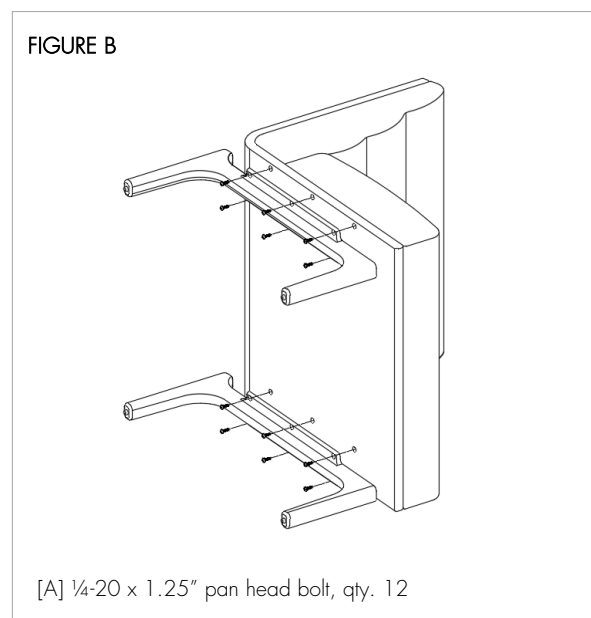
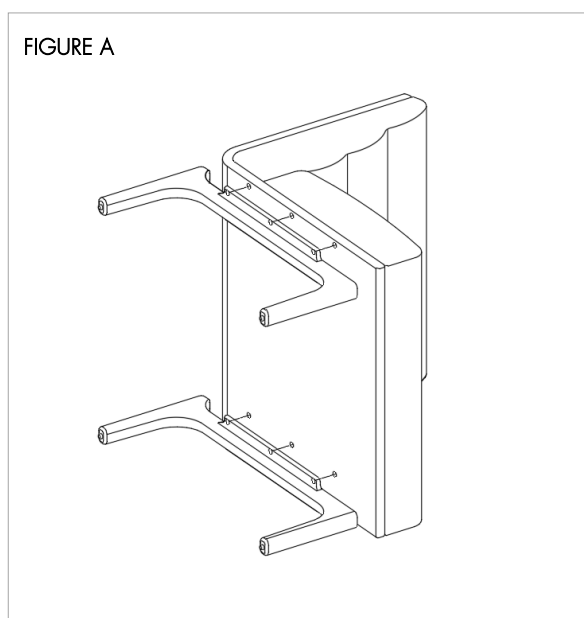

Note: Upon completion of Step 2, return the unit to upright position by lifting unit. Do not tilt or lean unit to upright position.

continued on next page

- Step 3: Open the privacy panel to reveal the attachment holes. Starting with the back of the chair, align the holes with the pre-inserted t-nuts and secure with (6) 1/4-20 x 1.1875" flat head bolts [B]. Follow with side panels using (5) 1/4-20 x 1.1875" flat head bolts [B] per side (Figure C).
- Step 4: Using an Allen wrench, align each corner bracket [D] to a side panel, thread the (3) 1/4-20 x .25" flat head bolts [C] into the pre-inserted t-nuts and securely tighten (Figure D).
- Step 5: Open the side panel where the straight bracket [E] will attach. Align the bracket with the pre-inserted t-nuts and use an Allen wrench to secure with (3) 1/4-20 x .25" flat head bolts [C] (Figure E).
- Step 6: Once the bracket is secured, remove the yellow masking tape covering the Velcro and firmly press the panels together (Figure F).

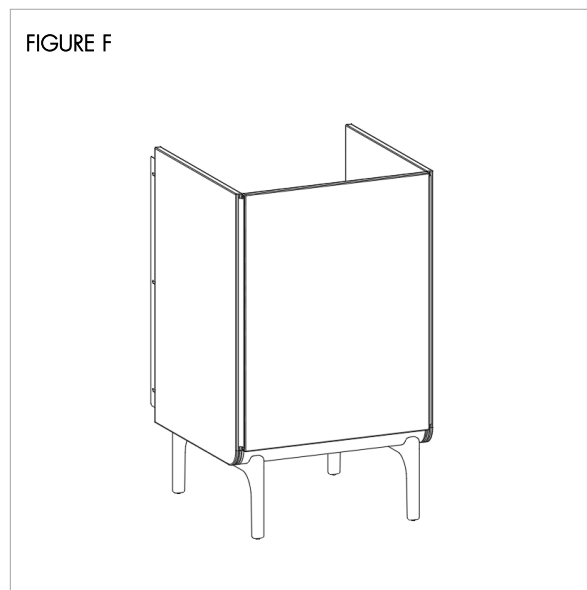
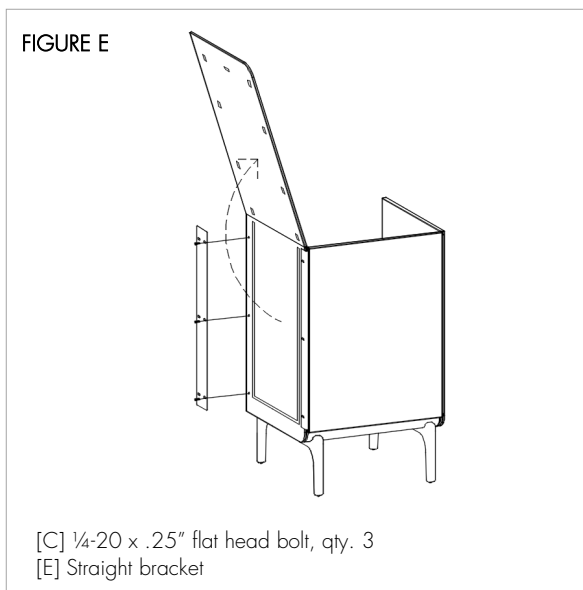
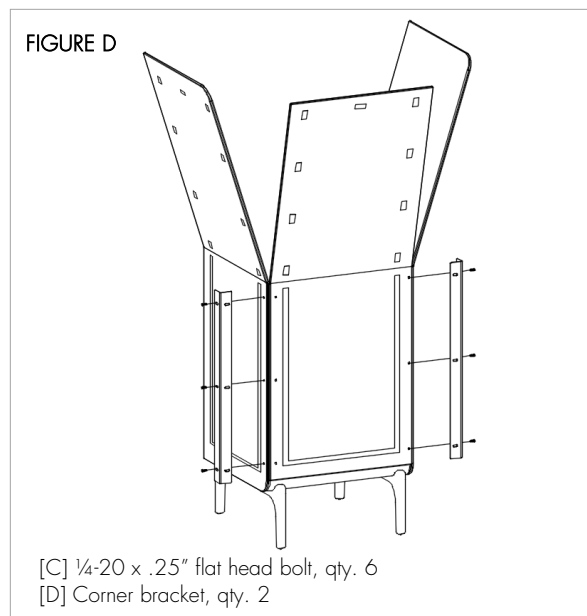
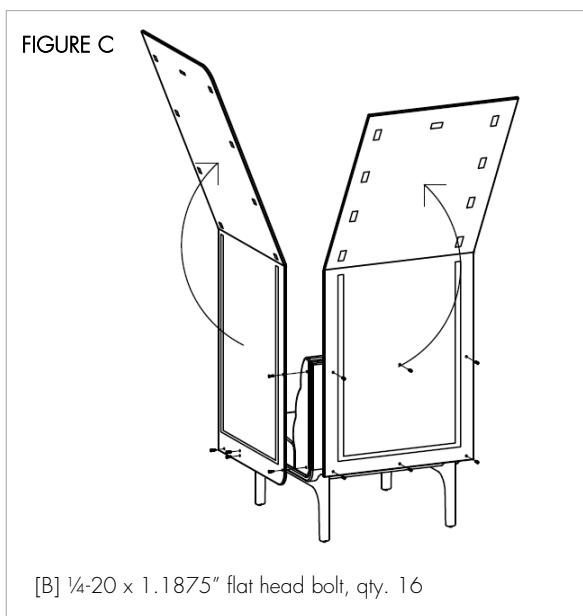

continued on next page

Step 7: Repeat steps 3 and 4 for the second seating unit. Open the side panel where the other half of the straight bracket will attach and arrange the units as they should be configured. Align the straight bracket from the already installed unit to the pre-inserted t-nuts on the secondary unit. Using an Allen wrench, secure together with (3) 1/4-20 x .25" flat head bolts [C] (Figure G).

Step 8: Once the bracket is secured, remove the yellow masking tape covering the Velcro and firmly press the panels together (Figure F).

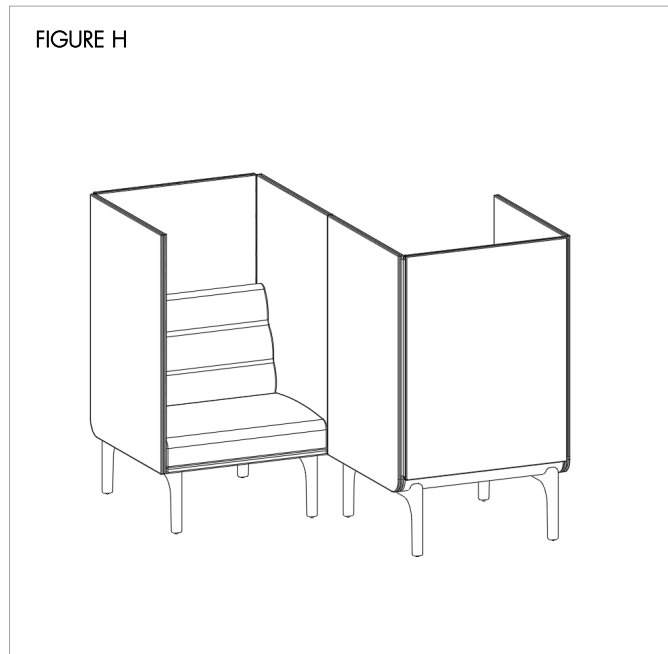
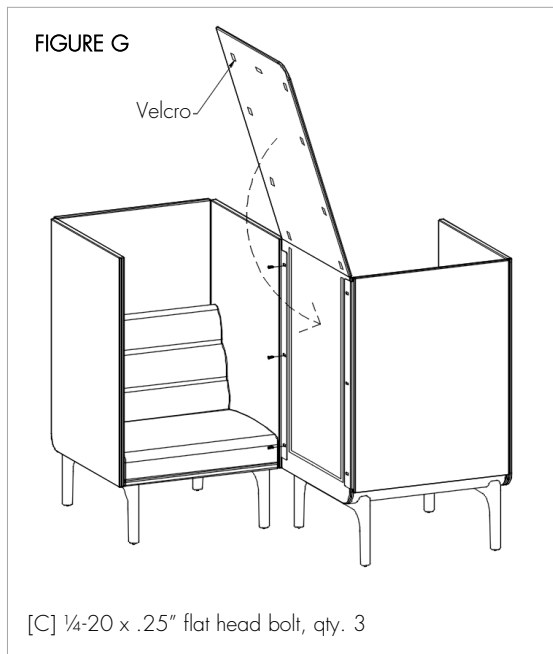

If you require additional assistance, please contact Arcadia Client Services at 800.585.5957.