

CO-OP ASSEMBLY INSTRUCTIONS – MODELS 6533 & 6535

Hardware Included:

- [A] 5/16-18 x 2" hex bolt (28)
- [B] Washer (28)
- [C] Anchor bolts (4)
- [D] 1/4-20 x 2" hex bolt (4)
- [E] 1/4-20 x .75" decorative screws (8)

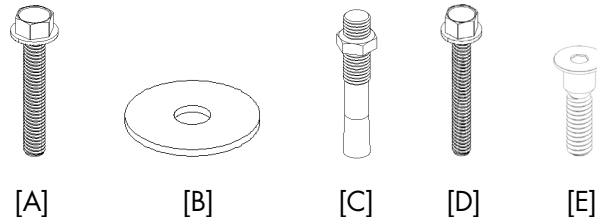

IMPORTANT – HARDWARE IS SPECIFIC FOR THE ASSEMBLY OF EACH COMPONENT. MAKE SURE THE CORRECT ITEMS ARE USED AS DIRECTED AND IDENTIFIED BELOW.

Step 1: Place seating unit on top of the plinth base. Using (6) 5/16-18 x 2" hex bolts [A] and washers [B], secure together by threading hardware through the inside of the seat into pre-inserted t-nuts (Figure A).

Step 2: Attach the back panel to the seat by placing it on top of the plinth base. Using (6) 5/16-18 x 2" hex bolts [A] and washers [B], secure together by threading hardware through the inside of the seat into the pre-inserted t-nuts on the back panel (Figure B).

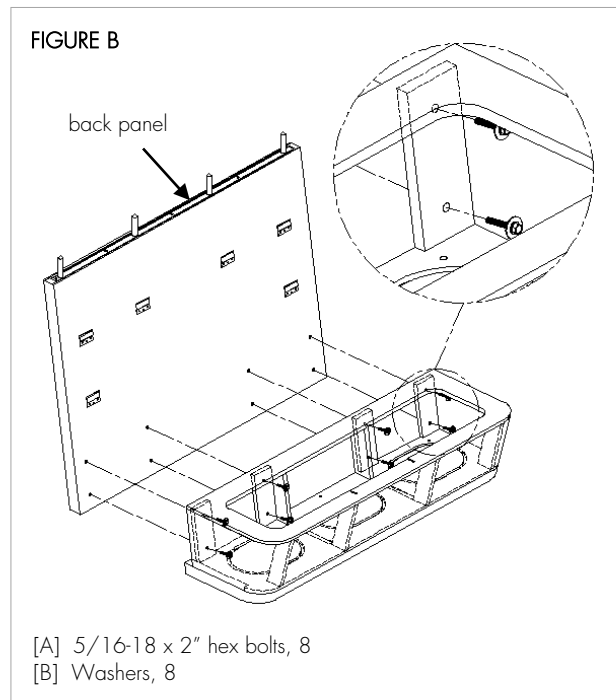
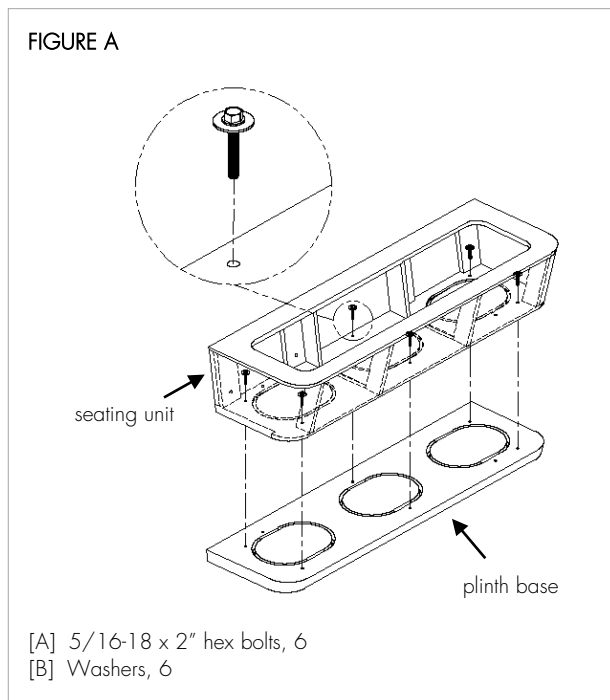

continued next page

- Step 3: Once both seating units have been assembled, place them approximately 41.5" apart, plinth to plinth (measurement is taking from the bottom front of both plinths). Attach the accent tiers by aligning them to the pins on the seating unit (Figure C).
- Step 4: With accent tiers properly secured, build canopy next. Start by inserting the attachment pins from the canopy elbows into the center canopy components' bushings. Using a 3/16 Allen key, secure together through the top using (48 1/4-20" x .75" decorative screws [E], four per side (Figure D).
- Step 5: Once the canopy is fully built and secured, align the attachment pins on the canopy to the bushings on top of the accent tier and gently push down until canopy is flat against the accent tiers (Figure E).
- Step 6: With the canopy installed, make certain the seating units are flat against the ground for installing anchor bolts. If using sandbags, place inside seating units (150 lbs. each side) and go to step 7. Place (4) anchor bolts [C], two per seating unit, in the four pre-drilled holes from the inside of the seats and properly secure the unit to the floor (Figure F).

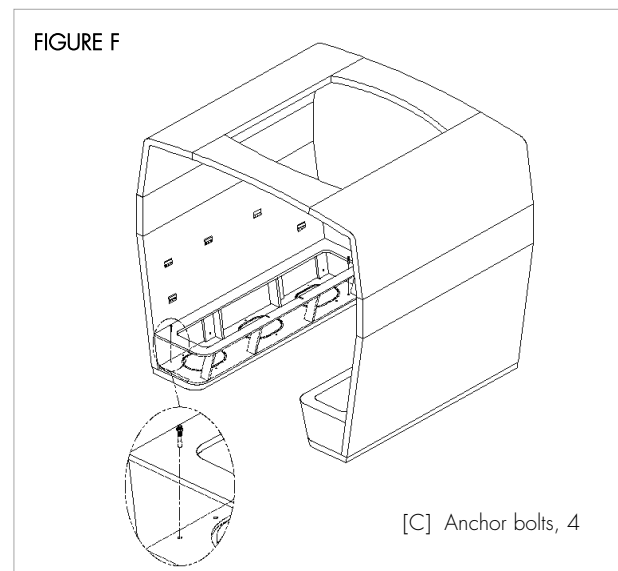
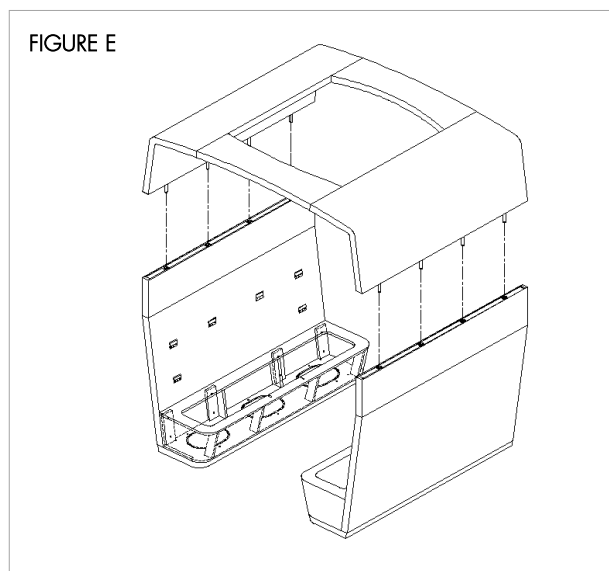
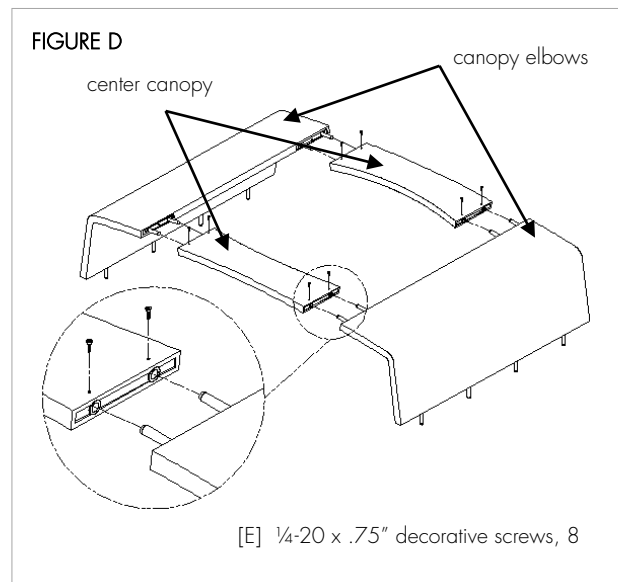
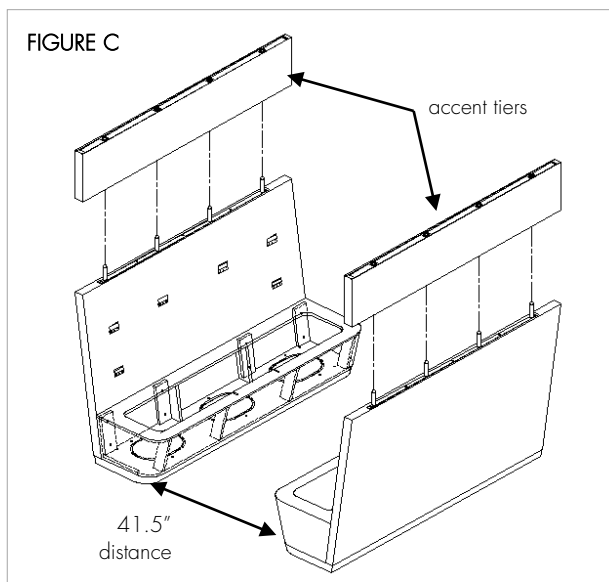

continued next page

Step 7: To install the seats, tilt the seat cushion slightly down in front. Locate the two 1/4-20 x 2" hex bolts underneath the seat cushion and slide into the notches on the seat frame while pushing down until it is flat (Figure G).

Step 8: To install the backs, align the z-brackets on the back rest with the z-brackets on the back panel (Figure H). Gently push down until back is positioned above the seat cushion.

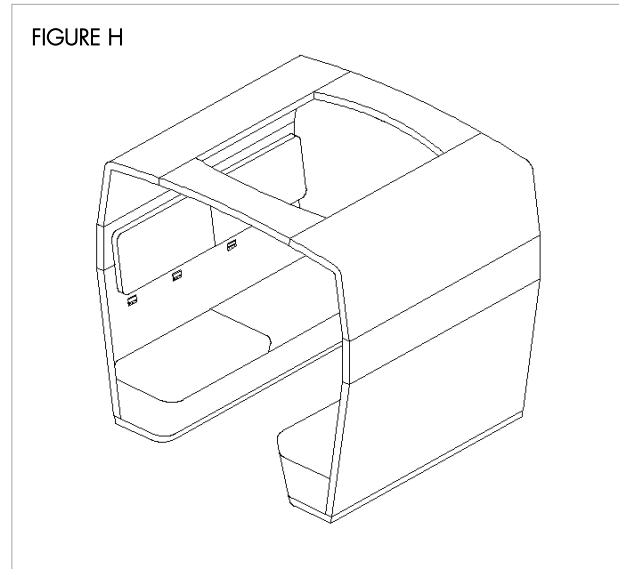
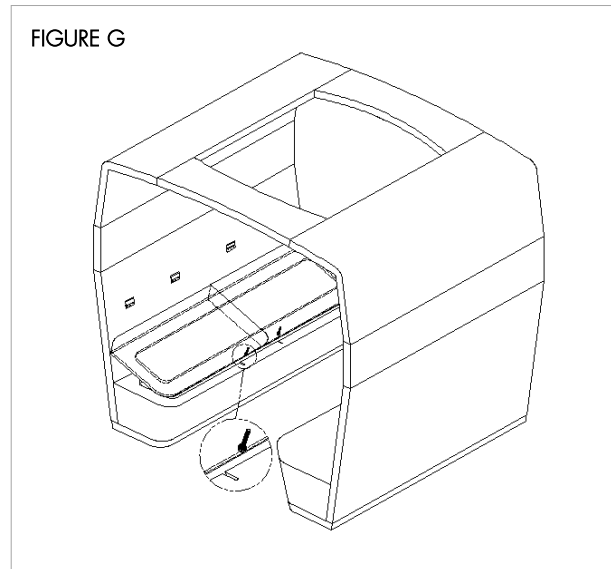

If you require additional assistance, please contact Arcadia Client Services at 800.585.5957.