

## CO-OP ASSEMBLY INSTRUCTIONS – MODEL 6510

Hardware Included:

[A] 5/16-18 x 2" hex bolt (4)

[B] 3/5 x 5" anchor bolt (4)

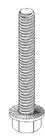

[A]



[B]

**IMPORTANT – HARDWARE IS SPECIFIC FOR THE ASSEMBLY OF EACH COMPONENT. MAKE SURE THE CORRECT ITEMS ARE USED AS DIRECTED AND IDENTIFIED BELOW.**

- Step 1: Remove the back cushions on the seating units by gently applying upward force to release it from the z-brackets that are holding it in place (Figure A).
- Step 2: With the back removed, slightly tilt the back of the seat cushion upwards, approximately 45-degrees, and pull until it comes out (Figure B).
- Step 3: Face the two seating units approximately 42.75" away from each other (measurement is taken from bottom front of both plinth bases). Align the wing brackets on the seating units with the wing brackets on the back panel. Secure the seats to the back panel by using (4) 5/16-18 x 2" hex bolts [A], two per seat from the inside of the seat. Bolts go into the pre-inserted t-nuts in the back panel (Figure C).

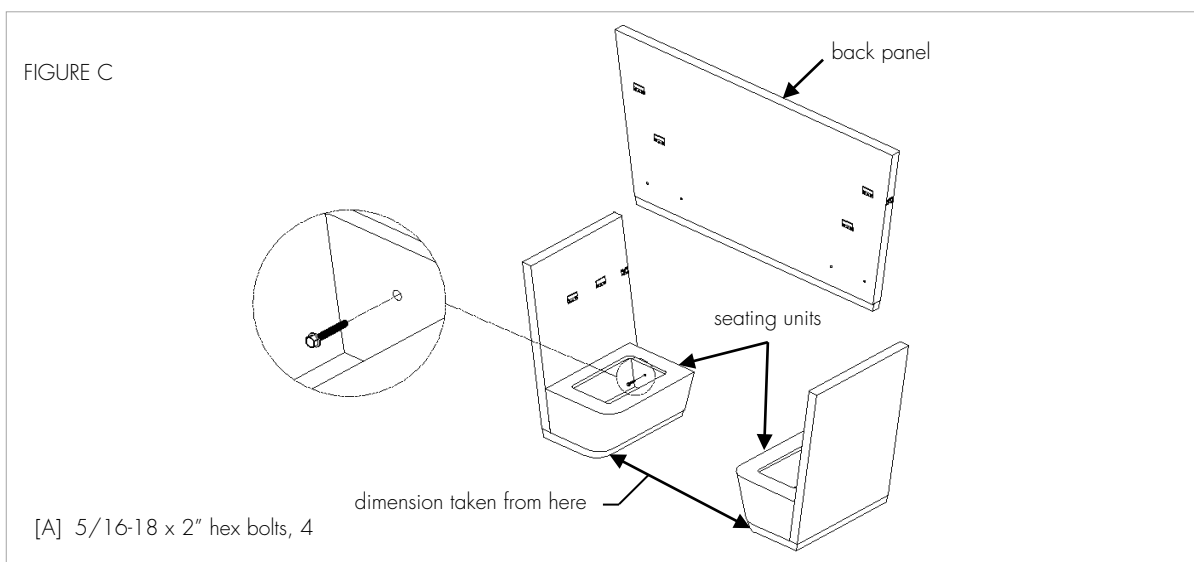
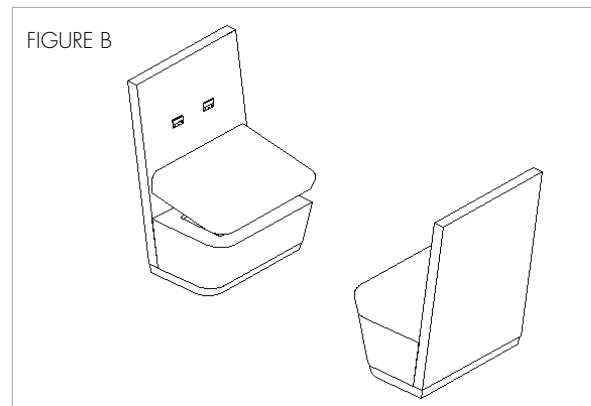
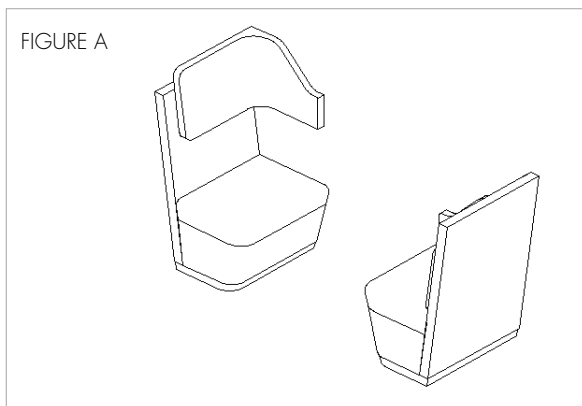

- Step 4: Securing the unit using anchor bolts or sandbags is optional. Skip to Step 5 if neither is being utilized. To secure the unit to the floor, first drill the floor using the predrilled holes as guides. Affix (4) 3/8 x 5" anchor bolts [B], two per seating unit (Figure D). If using sandbags, simply place them inside the seating units, two bags per side.
- Step 5: To install the seats, tilt the seat slightly upward making sure the 1/4-20 x 2" hex bolts underneath the seat cushion slide into the notches. Push the seat cushion down until it is flat against the seating unit (Figure E).
- Step 6: To install the backs, align the four z-brackets on the back rest with the four z-brackets on the seating units and gently push down until the back is flat on the top of the seat (Figure F).

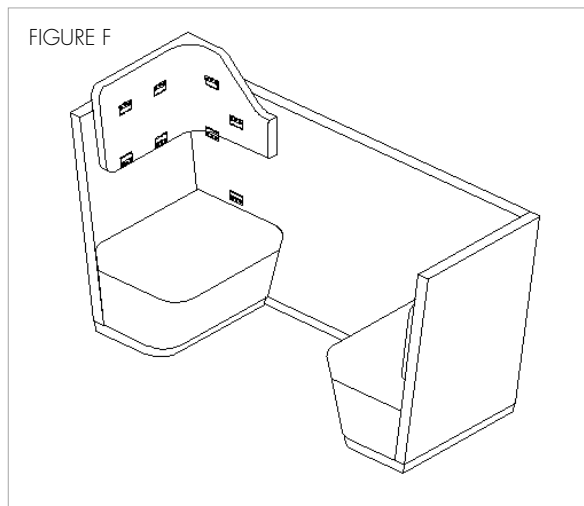
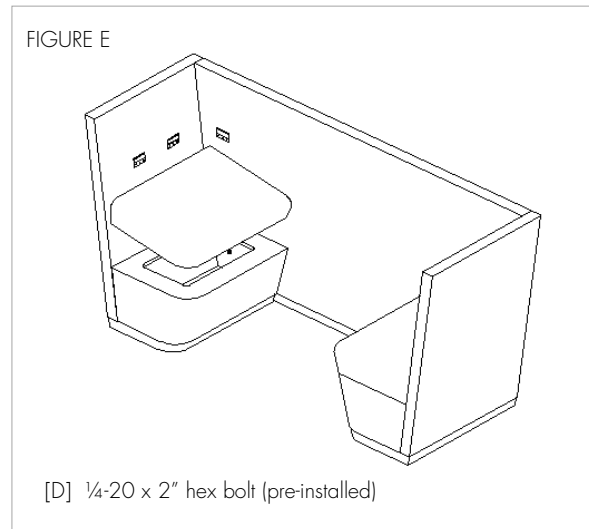
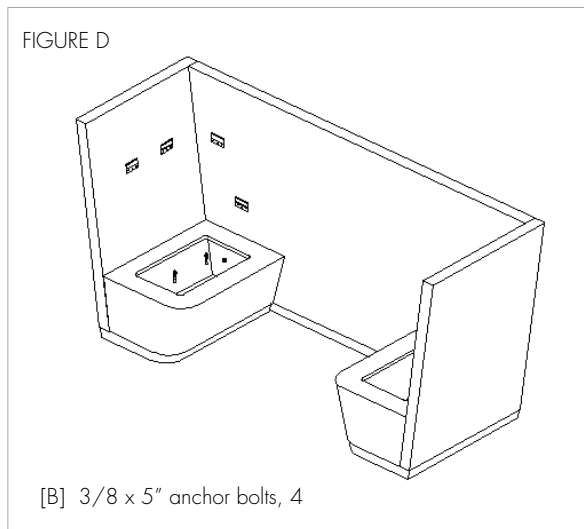

If you require additional assistance, please contact Arcadia Client Services at 800.585.5957.